

BOX MTS

ELECTRONIC CLAMP FOR DOOR AND DRAWERS



OPTIONAL KIT DOOR.

Incorporated system that holds the four corners in position to ensure precise clamping



All maneuvers controlled by control panel with touchscreen



The BOX MTS is an extremely versatile, high-performance electronic clamp with servomotor technology, ideal for the production of wide variety of drawers and doors of differing dimensions at high work-rates and a capacity for internally storing thousands of configurations.

It is extremely effective with any type of joint (smooth miter, shank, dovetail etc.) and thanks to the special clamping modes, folding connections and drawer fronts with glass insets can be clamped without damage. The electronic system of movement and tightening by servomotors, together with the use of linear guides, means perfect connection and the squareness of the finished product every time.

Configuration, memory access and all aspects of production are managed by a touchscreen control terminal, with an optional barcode scanner also able to access the saved configurations. Production lists created externally can also be saved to it via Ethernet connection.

TECHNICAL SPECIFICATIONS

CLAMPING DIMENSIONS

Maximum/minimum length (X)	1.600/230 mm
Maximum/minimum height (Y)	840/205 mm
Maximum/minimum depth (Z)	250/10 mm
Maximum oversized frontal (V)	40 mm
Maximum front thickness (T)	35 mm

CLAMPING FORCE

Maximum lateral force	1.200 Kg
Maximum vertical force	1.200 Kg

ELECTRICAL CONNECTION

Voltage	400 v
Electrical power	3.0 kW

PNEUMATIC CONNECTION

Working pressure	4 Bar
Consumption	4 NI/Cycle

OVERALL DIMENSIONS/WEIGHT

Length x Height x Width (L x H x W)	2.710 x 2.000 x 950 mm
Weight	470 Kg

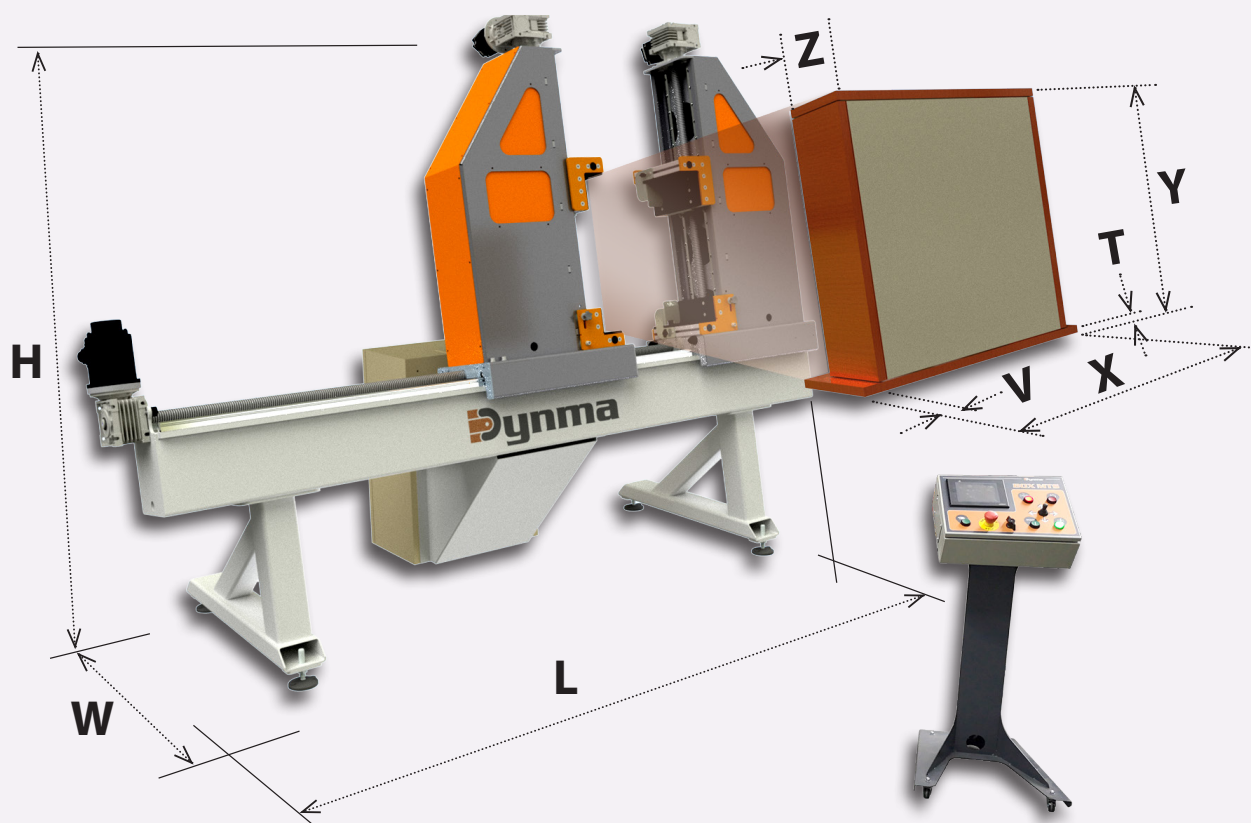

Dynma[®]

PATENTED MODEL. Copyright 2025 Desarrollo Industrial de Maquinaria Benicarló S.L.
The information contained in this document is subject to change and therefore is not binding.
Dynma is a registered trademark of Desarrollo Industrial de Maquinaria Benicarló S.L.

CV-135, km. 20.1 Pol. Ind. Mercado de abastos, Calle P, nave 10
12580 Benicarló (Castellón) Spain

Distributed by:



 (+34) 964 470 156

 www.dynma.es
dpto.comercial@dynma.es

 Dynma-Desarrollo Industrial de Maquinaria
Benicarlo S.L.